

TIMKEN**The Timken Company**

4500 Mt Pleasant St. NW

N. Canton, OH 44720

Phone: (234) 262-3000

E-Mail: CustomerCAD@timken.com • Web site: www.timken.com

Part Number 3205 ATN1/ZZ, Timken® Double Row Angular Contact Ball Bearings (3200, 3300)

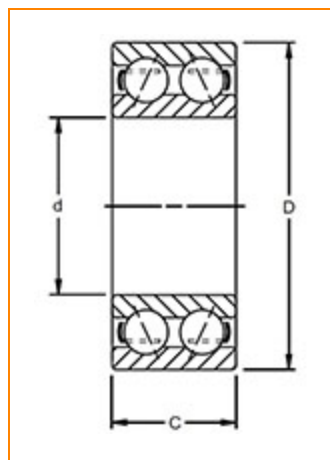

[Dimensions](#) | [Specifications](#) | [Basic Load Ratings](#) | [Abutment and Fillet Dimensions](#)

Dimensions

d - Bore	25.00 mm 0.9843 in
D - Outer Diameter	52.00 mm 2.0472 in
C - Ring Width	20.6 mm 0.8110 in
Contact Angle	30 °

Specifications

Features	Shields
Ball Type	STEEL



Cage Type	Molded
Cage Material	Nylon
Bearing Weight	0.18 Kg 0.404 lb
Design Units	METRIC

Basic Load Ratings

C0 - Static Radial Rating	12000 N 2697 lbf
C1 ISO - Dynamic Radial Rating	16300 N 3664 lbf

Abutment and Fillet Dimensions

R - Inner Ring "To Clear" Radius ¹	1.00 mm 0.039 in
r - Outer Ring "To Clear" Radius ²	1.00 mm 0.039 in
da - Inner Ring Backing Diameter	31.0 mm 1.220 in
Da - Outer Ring Backing Diameter	46.00 mm 1.8110 in

¹ Maximum housing fillet radius that bearing corners will clear.

² Maximum shaft fillet radius that bearing corners will clear.

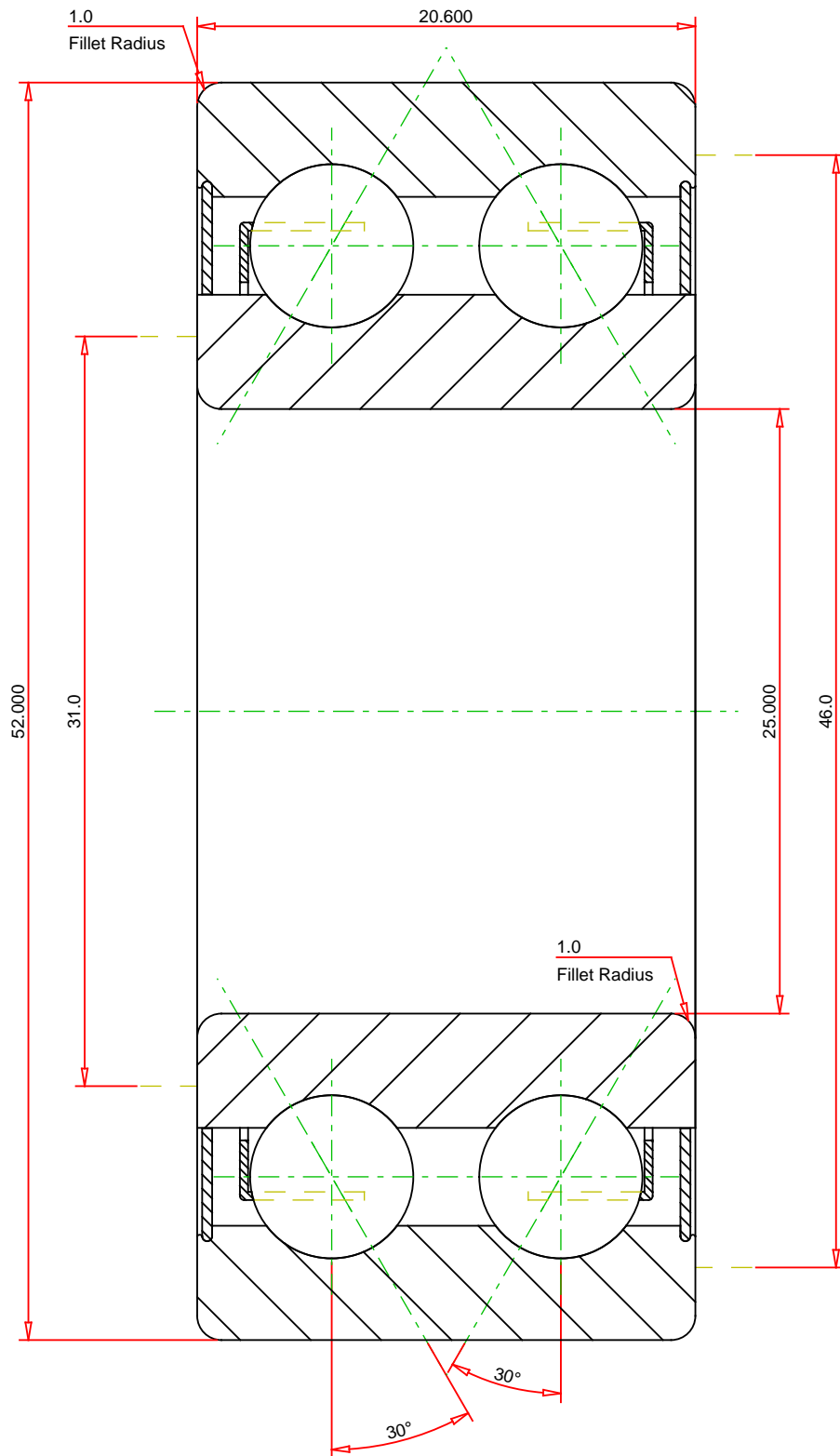

METRIC UNITS

Number of Balls Per Row	20
Bearing Weight	0.180 kg

TIMKEN®

THE TIMKEN COMPANY
NORTH CANTON, OHIO USA

3205 ATN1/ZZ	
Timken® Double Row Angular Contact Ball Bearings (3200, 3300)	
Dynamic Load Rating	16300 N
Static Load Rating	12000 N

Every reasonable effort has been made to ensure the accuracy of the information contained in this writing, but no liability is accepted for errors, omissions or for any other reason.

FOR DISCUSSION ONLY